

# AFN OUTDOOR TERMINATIONS

Up to 42 kV

6/10 (12) kV  
 6.35/11 (12) kV  
 8.7/15 (17.5) kV  
 12/20 (24) kV  
 12.7/22 (24) kV  
 18/30 (36) kV  
 20.8/36 (41.5) kV

## Application

A kit of 3 terminations for use outdoors and exposed to prolonged sunshine and other weather conditions.

To connect polymeric insulated cable to equipment and for the outdoor terminating on to overhead lines or bus bars.

## Design

Outdoor termination comprising:

1. Cable lug (not included in the standard kit).
2. Water sealing silicone sleeve.
3. Silicone housing with sheds and integrated conductive silicone rubber insert providing stress relief for the cable.
4. Water sealing mastic.
5. Earthing clamp.
6. Earthing lug (not included in the standard kit).

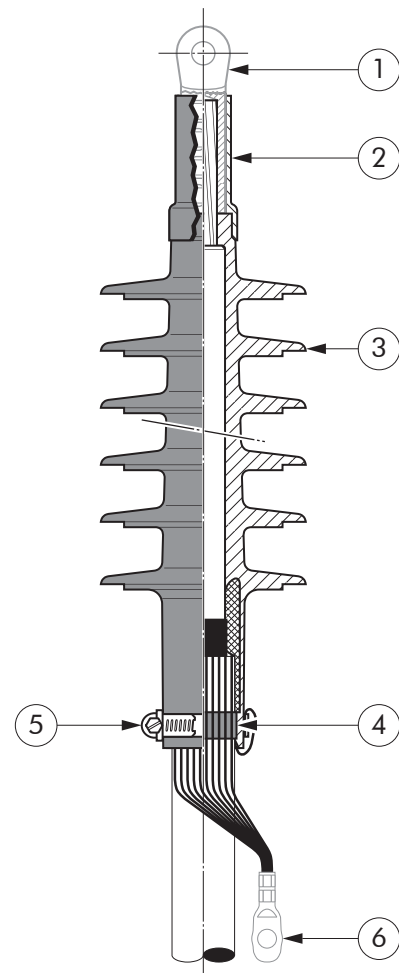

## Specifications and standards

Meets the requirements of CENELEC HD 629.1 and IEC 60502-4.

Termination type	Voltage $U_m$ (kV)	Conductor sizes (mm <sup>2</sup> )	
		min.	max.
AFN 10	12	25	1000
AFN 20	24	35	1000
AFN 30	36	50	800
AFN 36	42	150	800

01/2010

## Kit contents

A kit always comprises  
 3 termination housings, water  
 sealing sleeve, the installation  
 instructions, special lubricant,  
 wiper, earthing clamp, water  
 sealing mastic, adhesive tape,  
 field control mastic, ...  
 Cable lugs and earthing  
 lugs are not included in the  
 standard kit, but can be  
 ordered separately.

## Ordering instructions

Select the part number  
 corresponding to both the  
 system voltage and the cable  
 dimensions in mm.

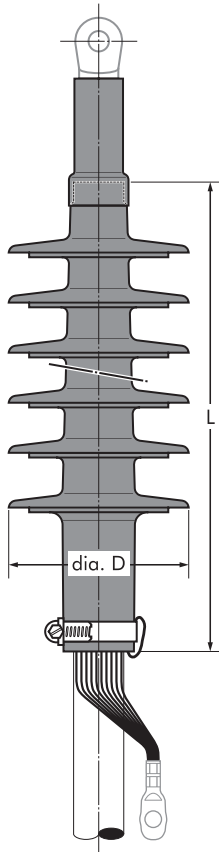

Voltage Um (kV)	Conductor sizes (mm <sup>2</sup> )		Diameter over core insulation (mm)		Number of sheds	L (mm)	Dia. D (mm)	Creepage distance (mm)	Ordering part number
	min.	max.	min.	max.					
12	25	95	13.5	20.8	3	150	90	369	3 x AFN 10-1-H
	120	240	19.4	28.4	3	150	96	365	3 x AFN 10-2-H
	300	500	27.4	36.6	3	150	105	360	3 x AFN 10-3-H
	800	1000	40.0	55.5	7	330	127	749	3 x AFN 10-4-H
24	35	70	18.3	23.4	4	225	100	480	3 x AFN 20-1-H
	95	240	23.0	32.6	4	225	112	499	3 x AFN 20-2-H
	300	630	31.6	43.5	4	225	118	462	3 x AFN 20-3-H
	500	1000	40.0	55.5	7	330	127	749	3 x AFN 20-4-H
36	50	70	24.2	28.4	6	300	115	695	3 x AFN 30-1-H
	95	240	27.3	37.6	6	300	115	694	3 x AFN 30-2-H
	240	400	31.5	42.8	6	300	127	718	3 x AFN 30-3-H
	400	800	40.0	55.0	7	330	127	749	3 x AFN 30-4-H
42	150	300	31.5	42.8	7	330	127	749	3 x AFN 36-3-H
	400	800	40.0	55.0	7	330	127	749	3 x AFN 36-4-H

### Example:

A set of 3 outdoor terminations  
 for a 24 kV - 240 mm<sup>2</sup> stranded  
 aluminium cable with copper wire  
 screen without cable lugs.  
 The diameter over core insulation  
 is 30.4 mm.  
 Order a 3 x AFN 20-2-H  
 termination kit.

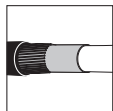

For use with copper  
 wire screened cables.  
 No earthing  
 device is  
 necessary.

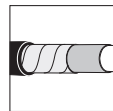

For use with  
 copper tape  
 screened cables.  
 Order: -/MT.



For use with  
 three-core cables.  
 Please contact our  
 representative.



For use with other  
 cable types.  
 Please contact our  
 representative.

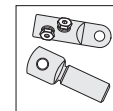

Can be supplied with  
 all common types of  
 cable lugs.



No heating or flame  
 is required.